

YK 200 Omni-Chef Specifications:

Cabinet Size

25.5" wide x 33" deep x 58.87" high
Overall Height w/ Casters – 64"

Food Racks

5 – 17.75" wide x 26" deep Stainless
Steel Flat Racks (5" rack spacing)
16.25 ft² Cooking Area
Will accommodate 18" x 26" sheet pans

Optional Stainless Steel Rib Racks

5 – 17.75" x 26" x 2" (13 ribs per rack)
Will hold 65 slabs of 2.5 lb or smaller ribs

Electrical Requirements

Accommodates 208/220/240 Volt AC, 50 thru
60hz, Single Phase, 50 Amp Wiring, 6300 Watts
of Combined Cook, Steam, and Smoke Power

Temperature Range

80° to 375° F

Digital Control

Digital Roast, Smoke, Steam, and Hold Control
with Dual Meat Probes, Menu Management
System with 40 Pre-Set Menus. The YieldKing
guides your product through five distinct
cooking stages automatically.

Cool-Down System

Allows for quick cool-down of cabinet for slow
roasting delicate whole muscles like prime rib.

Smoking

Smoking infuses unique flavors like exotic wood
smoke, aromatic herbs and citrus into your products.
You can even cold smoke while maintaining
a safe internal temperature.

Steaming

Impart multiple levels of flavor by adding beer, wine
or fruit juice to your steam pan water.

Natural Drippings Catch Pan

Unique catch pan allows you to capture and use
drippings, that you used to discard from your proteins
for sauces, gravies, Au Jus and stocks.



YieldKing Sales: 888-273-4456 • Sales Fax: 618-993-5960
Service: 888-273-4457

sales@yieldking.net • www.yieldking.net

5003 Meadowland Pky. • Marion, IL 62959

Revised 10/31/07

YK 200 Specifications:

Top View

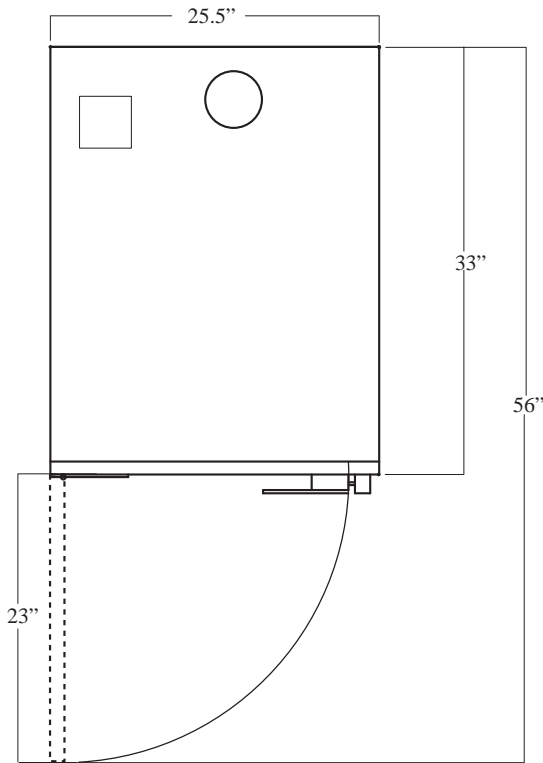

Cooking Capacities

Prime Rib (12-14 lb)	15
Pork Butts (7-8 lb)	30
Beef Brisket (10-12 lb)	15
Baby Back Ribs (1.75 lb & down)	65 w/ Rib Racks
St. Louis Ribs (2.75 lb & down)	65 w/ Rib Racks
Spare Ribs (3.5 lb & down)	39 w/ Rib Racks
Chickens (3 lb)	40

Venting:

The YieldKing 200 must be installed under a canopy hood rated for commercial cooking applications. Any ventilation system must be installed in accordance with local codes. Always consult with local code officials and a commercial kitchen ventilation contractor prior to installation.

Shipping Weight:

650 lbs. (50.4 cubic feet)

Crated Dimensions

72" x 28" x 50"

Patent Pending



Front View

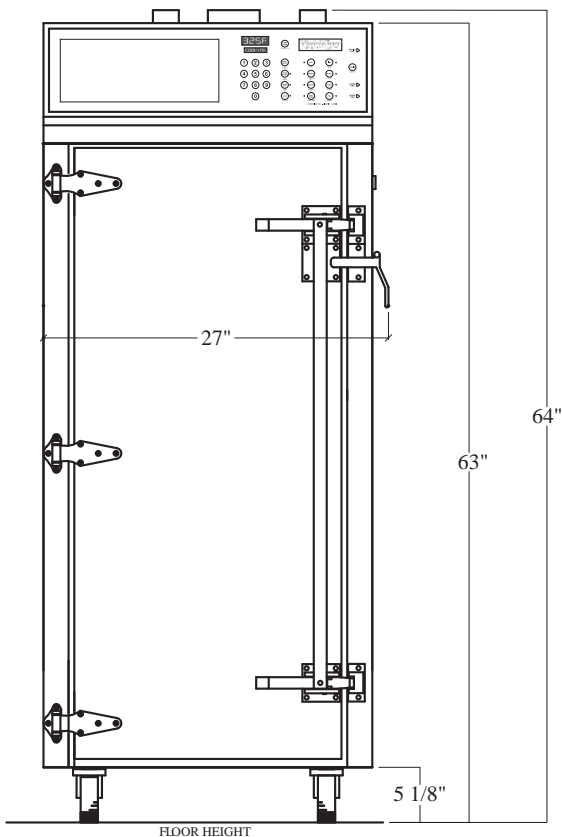

Side View

